

## Silicon Epitaxial Planar Switching Diode

### FEATURES

- Low forward voltage
- Fast reverse recovery time

### MARKING: E3

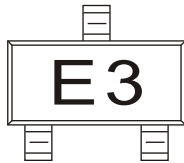

E3 = Device code

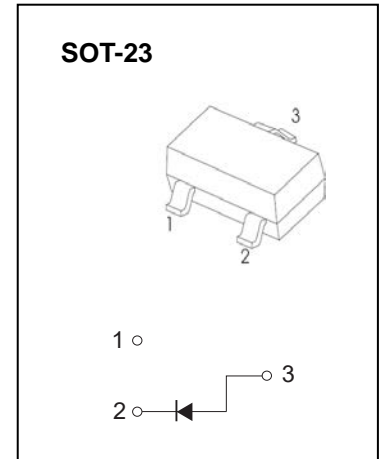

### Maximum Ratings @Ta=25°C

Parameter	Symbol	Limit	Unit
Non-Repetitive Peak Reverse Voltage	$V_{RM}$	85	V
DC Blocking Voltage	$V_R$	80	V
Forward Continuous Current	$I_{FM}$	300	mA
Average Rectified Output Current	$I_O$	100	mA
Non-Repetitive Peak Forward Surge Current @t=8.3ms	$I_{FSM}$	2.0	A
Power Dissipation	$P_D$	150	mW
Thermal Resistance from Junction to Ambient	$R_{\theta JA}$	833	°C/W
Operation Junction and Storage Temperature Range	$T_J, T_{STG}$	-55~+150	°C

### Electrical Characteristics @Ta=25°C

Parameter	Symbol	Min	Typ	Max	Unit	Conditions
Reverse breakdown voltage	$V_{(BR)}$	80			V	$I_R=100\mu A$
Forward voltage	$V_{F1}$		0.61		V	$I_F=1mA$
	$V_{F2}$		0.74		V	$I_F=10mA$
	$V_{F3}$		0.92	1.2	V	$I_F=100mA$
Reverse current	$I_{R1}$			0.1	$\mu A$	$V_R=30V$
	$I_{R2}$			0.5	$\mu A$	$V_R=80V$
Capacitance between terminals	$C_T$		2.2	4.0	pF	$V_R=0, f=1MHz$
Reverse recovery time	$t_{rr}$		1.6	4.0	ns	$I_F=I_R=10mA, I_{rr}=0.1 \times I_R$

## Typical Characteristics

