

NPN SILICON TRANSISTOR

POWER AMPLIFIER APPLICATIONS POWER SWITCHING APPLICATIONS

■ FEATURES

- * Low saturation voltage: $V_{CE(SAT)} = 0.5V$ (Max.)
- * High speed switching time: $T_{STG} = 1.0\mu s$ (Typ.)

MARKING : 2655

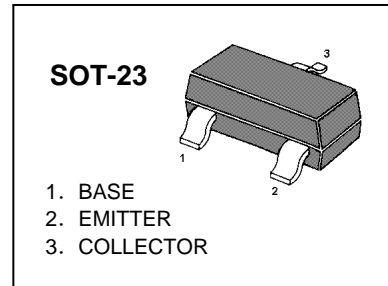

■ ABSOLUTE MAXIMUM RATINGS ($T_A = 25^\circ C$, unless otherwise specified)

PARAMETER	SYMBOL	RATING	UNIT
Collector-Base Voltage	V_{CBO}	50	V
Collector-Emitter Voltage	V_{CEO}	50	V
Emitter-Base Voltage	V_{EBO}	5	V
Collector Current	I_C	2	A
Collector Current (Pulse) (Note 1)	I_{CP}	3	A
Base Current	I_B	0.5	A
Collector Power Dissipation	SOT-23	350	mW
	TO-92	900	
Junction Temperature	T_J	150	$^\circ C$
Storage Temperature	T_{STG}	-55 ~ +150	$^\circ C$

Note: 1. $P_W \leq 16ms$, Duty Cycle $\leq 50\%$.

2. Absolute maximum ratings are those values beyond which the device could be permanently damaged. Absolute maximum ratings are stress ratings only and functional device operation is not implied.

■ ELECTRICAL CHARACTERISTICS ($T_A = 25^\circ C$, unless otherwise specified)

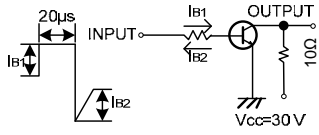
PARAMETER	SYMBOL	TEST CONDITIONS	MIN	TYP	MAX	UNIT
Collector Emitter Breakdown Voltage	BV_{CEO}	$I_C = 10mA, I_B = 0$	50			V
Collector Cut-off Current	I_{CBO}	$V_{CB} = 50V, I_E = 0$			1.0	μA
Emitter Cut-off Current	I_{EBO}	$V_{EB} = 5V, I_C = 0$			1.0	μA
DC Current Gain	$h_{FE(1)}$	$V_{CE} = 2V, I_C = 0.5A$	70		240	
	$h_{FE(2)}$	$V_{CE} = 2V, I_C = 1.5A$	40			
Collector-Emitter Saturation Voltage	$V_{CE(SAT)}$	$I_C = 1A, I_B = 0.05A$			0.5	V
Base- Emitter Saturation Voltage	$V_{BE(SAT)}$	$I_C = 1A, I_B = 0.05A$			1.2	V
Transition Frequency	f_T	$V_{CE} = 2V, I_C = 0.5A$		100		MHz
Collector Output Capacitance	C_{OB}	$V_{CB} = 10V, I_E = 0, f = 1MHz$		30		pF
Switching Time(Turn-on Time)	t_{ON}	 <p>$I_{B1} = -I_{B2} = 0.05A$ DUTY CYCLE $\leq 1\%$</p>		0.1		μs

■ CLASSIFICATION OF $h_{FE(1)}$

RANK	O	Y
RANGE	70-140	120-240

2SC2655

NPN SILICON TRANSISTOR

TYPICAL CHARACTERISTICS

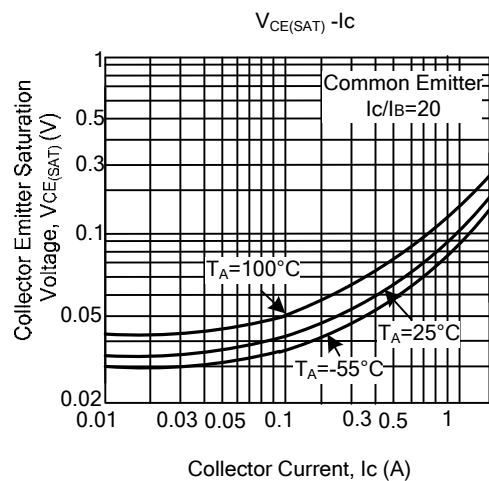
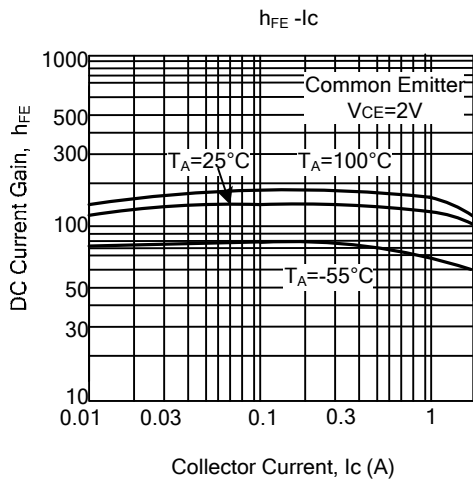
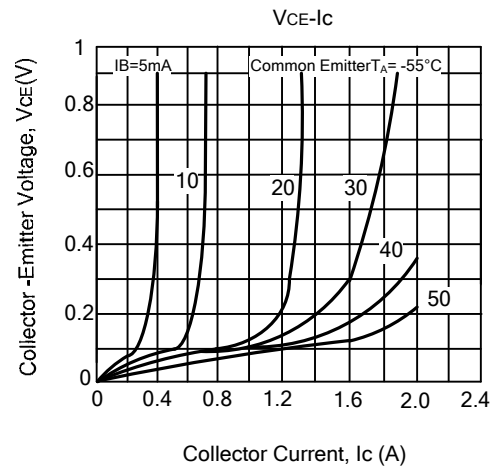
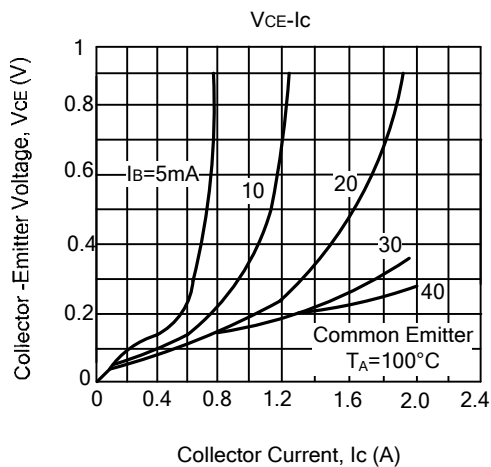
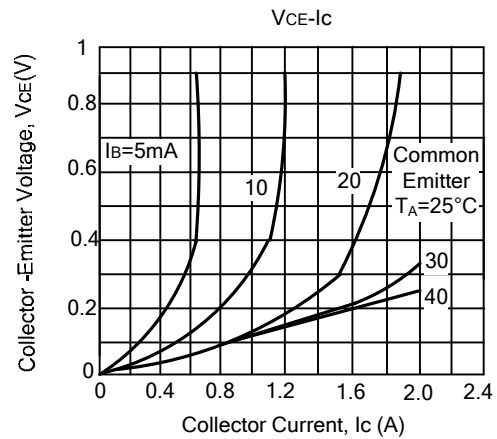
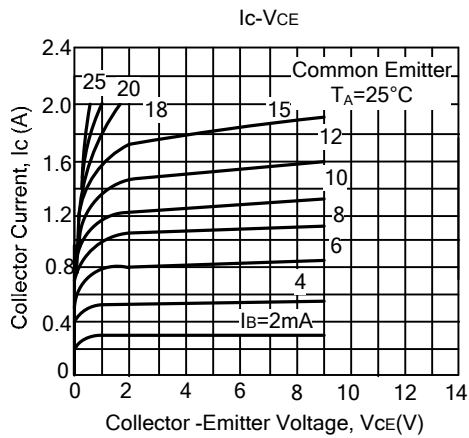

2SC2655

NPN SILICON TRANSISTOR

■ TYPICAL CHARACTERISTICS(Cont.)

