

## SOT-23 Plastic-Encapsulate Transistors

TRANSISTOR (NPN)

### FEATURES

- Excellent  $h_{FE}$  Linearity
- Switching Applications

### MAXIMUM RATINGS ( $T_a=25^\circ\text{C}$ unless otherwise noted)

Symbol	Parameter	Value	Unit
$V_{CB0}$	Collector-Base Voltage	35	V
$V_{CE0}$	Collector-Emitter Voltage	30	V
$V_{EB0}$	Emitter-Base Voltage	5	V
$I_C$	Collector Current	500	mA
$P_C$	Collector Power Dissipation	150	mW
$R_{\theta JA}$	Thermal Resistance From Junction To Ambient	833	$^\circ\text{C/W}$
$T_J, T_{stg}$	Operation Junction and Storage Temperature Range	-55~+150	$^\circ\text{C}$

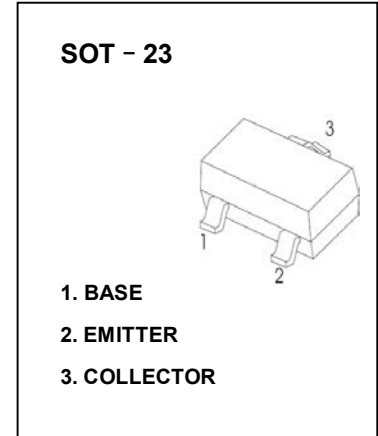

### ELECTRICAL CHARACTERISTICS ( $T_a=25^\circ\text{C}$ unless otherwise specified)

Parameter	Symbol	Test conditions	Min	Typ	Max	Unit
Collector-base breakdown voltage	$V_{(BR)CBO}$	$I_C=100\mu\text{A}, I_E=0$	35			V
Collector-emitter breakdown voltage	$V_{(BR)CEO}$	$I_C=1\text{mA}, I_B=0$	30			V
Emitter-base breakdown voltage	$V_{(BR)EBO}$	$I_E=100\mu\text{A}, I_C=0$	5			V
Collector cut-off current	$I_{CBO}$	$V_{CB}=35\text{V}, I_E=0$			0.1	$\mu\text{A}$
Emitter cut-off current	$I_{EBO}$	$V_{EB}=5\text{V}, I_C=0$			0.1	$\mu\text{A}$
DC current gain	$h_{FE(1)}$	$V_{CE}=1\text{V}, I_C=100\text{mA}$	70		400	
	$h_{FE(2)}$	$V_{CE}=6\text{V}, I_C=400\text{mA}$	25			
Collector-emitter saturation voltage	$V_{CE(sat)}$	$I_C=100\text{mA}, I_B=10\text{mA}$			0.25	V
Base-emitter voltage	$V_{BE}$	$V_{CE}=1\text{V}, I_C=100\text{mA}$			1	V
Transition frequency	$f_T$	$V_{CE}=6\text{V}, I_C=20\text{mA}$		300		MHz
Collector output capacitance	$C_{ob}$	$V_{CB}=6\text{V}, I_E=0, f=1\text{MHz}$		7		pF

### CLASSIFICATION OF $h_{FE(1)}, h_{FE(2)}$

RANK	O	Y	GR(G)
RANGE $h_{FE(1)}$	70 - 140	120 - 240	200 - 400
RANGE $h_{FE(2)}$	25Min	40Min	40Min
MARKING	WO	WY	WG

## Typical Characteristics

