

SOT-23 Plastic-Encapsulate Transistors

2SC3545 TRANSISTOR (NPN)

FEATURES

- Collector Current Capability $I_C=50\text{mA}$
- Collector Emitter Voltage $V_{CEO}=15\text{V}$

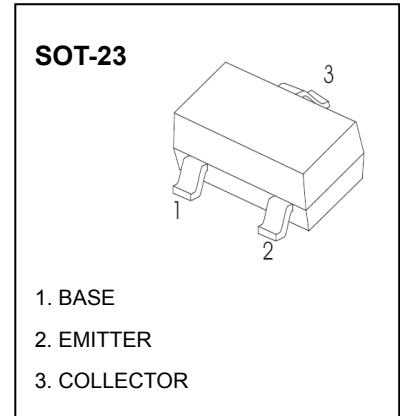

■ Absolute Maximum Ratings $T_a = 25^\circ\text{C}$

Parameter	Symbol	Rating	Unit
Collector - Base Voltage	V_{CBO}	30	V
Collector - Emitter Voltage	V_{CEO}	15	
Emitter - Base Voltage	V_{EBO}	3	
Collector Current - Continuous	I_C	50	mA
Collector Power Dissipation	P_C	150	mW
Junction Temperature	T_J	125	°C
Storage Temperature Range	T_{stg}	-65 to 125	

■ Electrical Characteristics $T_a = 25^\circ\text{C}$

Parameter	Symbol	Test Conditions	Min	Typ	Max	Unit
Collector- base breakdown voltage	V_{CBO}	$I_C = 100 \mu\text{A}, I_E = 0$	30			V
Collector- emitter breakdown voltage	V_{CEO}	$I_C = 1 \text{mA}, I_B = 0$	15			
Emitter - base breakdown voltage	V_{EBO}	$I_E = 100 \mu\text{A}, I_C = 0$	3			
Collector-base cut-off current	I_{CBO}	$V_{CB} = 12\text{V}, I_E = 0$			0.1	uA
Emitter cut-off current	I_{EBO}	$V_{EB} = 3\text{V}, I_C = 0$			0.1	
Collector-emitter saturation voltage	$V_{CE(sat)}$	$I_C = 10 \text{mA}, I_B = 1 \text{mA}$			0.5	V
Base - emitter saturation voltage	$V_{BE(sat)}$	$I_C = 10 \text{mA}, I_B = 1 \text{mA}$			1.2	
DC current gain	h_{FE}	$V_{CE} = 10\text{V}, I_C = 5 \text{mA}$	50		250	
Collector-base time constant	$C_{c\text{ rbb}}$	$V_{CB} = 10\text{V}, I_E = -5 \text{mA}, f = 31.9 \text{MHz}$			10	ps
Collector output capacitance	C_{ob}	$V_{CB} = 10\text{V}, I_E = 0, f = 1 \text{MHz}$			1	pF
Transition frequency	f_T	$V_{CE} = 10\text{V}, I_E = -5 \text{mA}$	1.3			GHz

■ Classification of h_{fe}

Type	2SC3545-T42	2SC3545-T43	2SC3545-T44
Range	50-100	70-140	120-250
Marking	T42	T43	T44

Typical Characteristics

