

## Digital Transistors (Built-in Resistors)

### DTA143XE/DTA143XUA DTA143XKA/DTA143XCA

DIGITAL TRANSISTOR (PNP)

#### FEATURES

- Built-in bias resistors enable the configuration of an inverter circuit without connecting external input resistors(see equivalent circuit)
- The bias resistors consist of thin-film resistors with complete isolation to allow positive biasing of the input.They also have the advantage of almost completely eliminating parasitic effects
- Only the on/off conditions need to be set for operation, making device design easy

#### • Equivalent Circuit

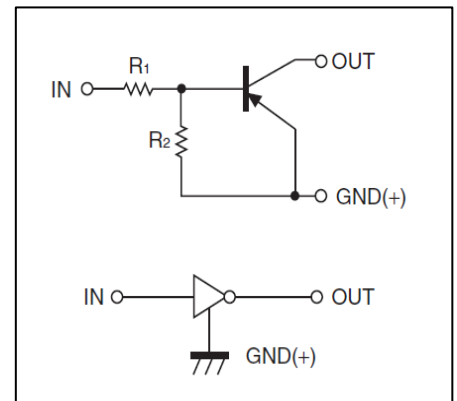

#### PIN CONNENCTIONS and MARKING

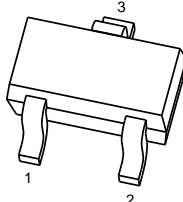
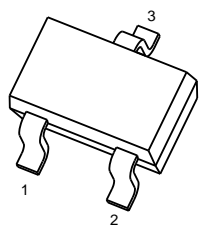
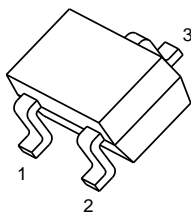
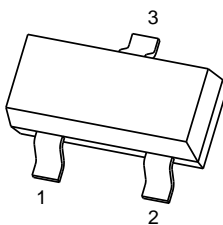
<p><b>DTA143XE</b></p>  <p><b>SOT-523</b></p> <p>1. IN 2. GND 3. OUT</p> <p><b>MARKING:33</b></p>	<p><b>DTA143XUA</b></p>  <p><b>SOT-323</b></p> <p>1. IN 2. GND 3. OUT</p> <p><b>MARKING:33</b></p>
<p><b>DTA143XKA</b></p>  <p><b>SOT-23-3L</b></p> <p>1. IN 2. GND 3. OUT</p> <p><b>MARKING:33</b></p>	<p><b>DTA143XCA</b></p>  <p><b>SOT-23</b></p> <p>1. IN 2. GND 3. OUT</p> <p><b>MARKING:33</b></p>

**MAXIMUM RATINGS(Ta=25°C unless otherwise noted)**

Symbol	Parameter	Limits(DTA143X□)				Unit
		E	UA	CA	KA	
V <sub>CC</sub>	Supply Voltage	-50				V
V <sub>IN</sub>	Input Voltage	-20~+7				V
I <sub>O</sub>	Output Current	-100				mA
P <sub>D</sub>	Power Dissipation	150	200	200	200	mW
T <sub>J</sub> ,T <sub>stg</sub>	Operation Junction and Storage Temperature Range	-55~+150				°C

**ELECTRICAL CHARACTERISTICS (Ta=25°C unless otherwise specified)**

Parameter	Symbol	Conditions	Min	Typ	Max	Unit
Input voltage	V <sub>I(off)</sub>	V <sub>CC</sub> =-5V,I <sub>O</sub> =-100μA	-0.3			V
	V <sub>I(on)</sub>	V <sub>O</sub> =-0.3V,I <sub>O</sub> =-20mA			-2.5	V
Output voltage	V <sub>O(on)</sub>	I <sub>O</sub> /I <sub>I</sub> =-10mA/-0.5mA		-0.1	-0.3	V
Input current	I <sub>I</sub>	V <sub>I</sub> =-5V			-1.8	mA
Output current	I <sub>O(off)</sub>	V <sub>CC</sub> =-50V,V <sub>I</sub> =0			-0.5	μA
DC current gain	G <sub>I</sub>	V <sub>O</sub> =-5V,I <sub>O</sub> =-10mA	30			
Input resistance	R <sub>1</sub>		3.29	4.7	6.11	kΩ
Resistance ratio	R <sub>2</sub> /R <sub>1</sub>		1.7	2.1	2.6	
Transition frequency	f <sub>T</sub>	V <sub>O</sub> =-10V,I <sub>O</sub> =-5mA,f=100MHz		250		MHz

## Typical Characteristics

